



Ferramenta Hardware
 Componenti Components
 Chiave esagonale Hexagonal key

 **n°1**

Distanziale (N) Spacer (N)
 **n°4**

Piedini (P) Feet (P)
 **n°4**

Rondella sp.16 (Q) Washer sp.16 (Q)
 **n°4**

Dado 6 MA (S) Nut 6 MA (S)
 **n°4**

Bullone 6x15 (T) Bolt 6x15 (T)
 **n°20**

Bullone 6x20 (U) Bolt 6x20 (U)
 **n°8**

Bullone 6x45 (V) Bolt 6x45 (V)
 **n°4**

Bullone 6x50 (Z) Bolt 6x50 (Z)
 **n°4**

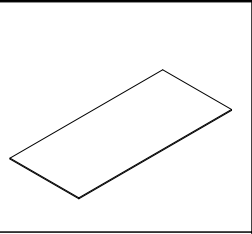

Piano (A)
 Top (A)

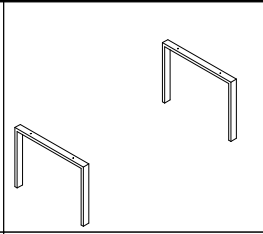

Gamba (B)
 Leg (B)

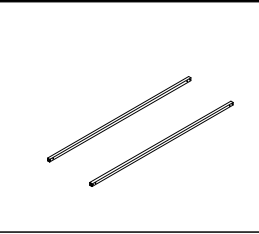

Travi (C)
 Crossbars (C)

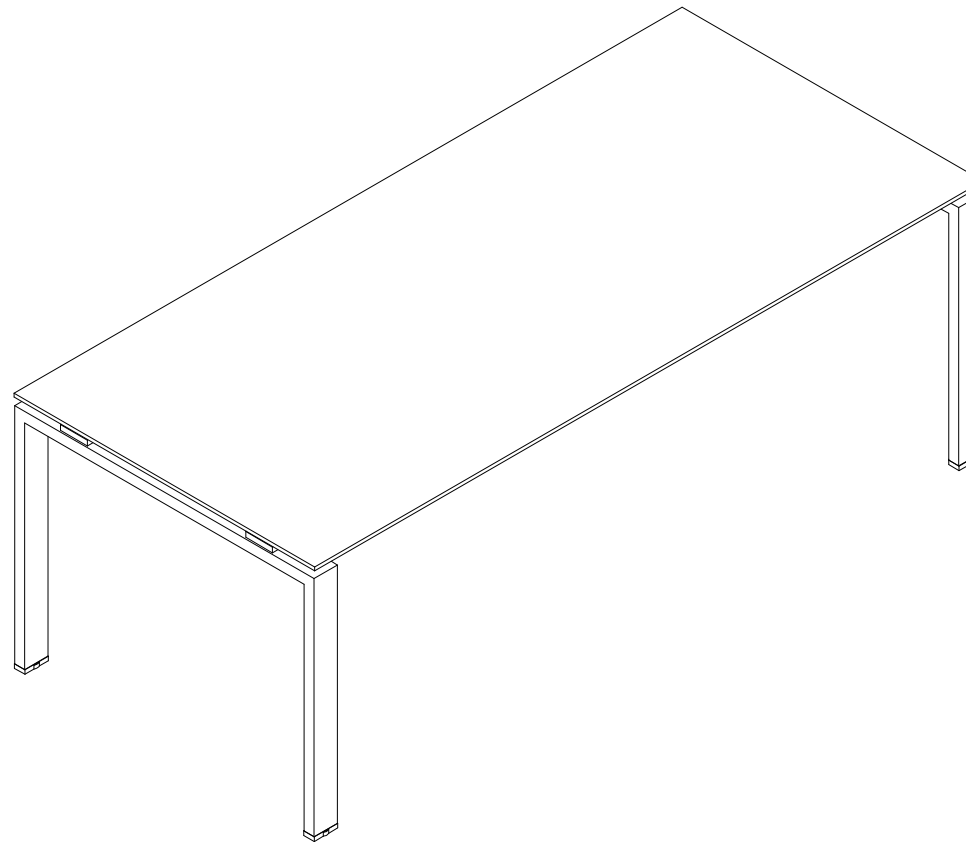

Fig.1 Fissare i bulloni (U) nei distanziali (N) delle gambe (B)
Fig.1 Fasten the bolts (U) in the spacers (N) of the legs (B)

1) Posizionare i distanziali (N) e i piedini (P), nelle gambe (B)
1) Position the spacer (N) and feet (P), in the legs (B)

2) Posizionare le travi (C) sulle gambe (B)
2) Position the crossbar (C) on the legs (B)

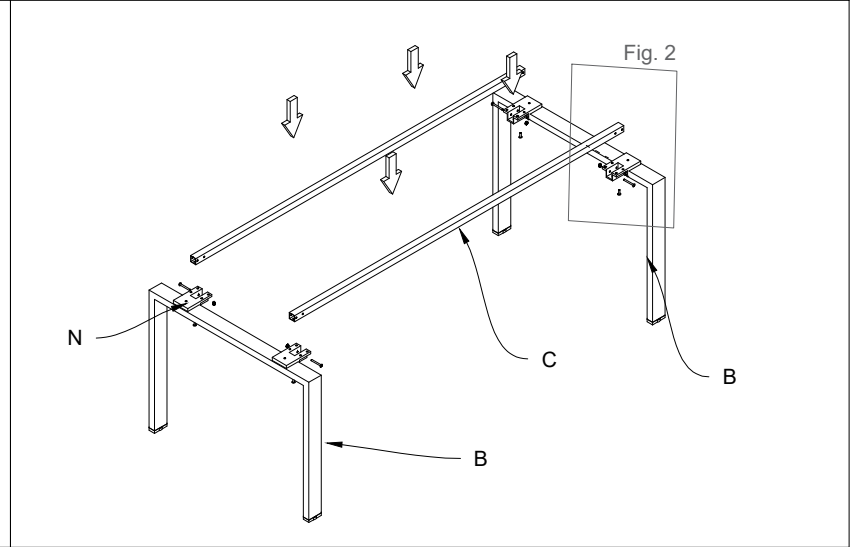
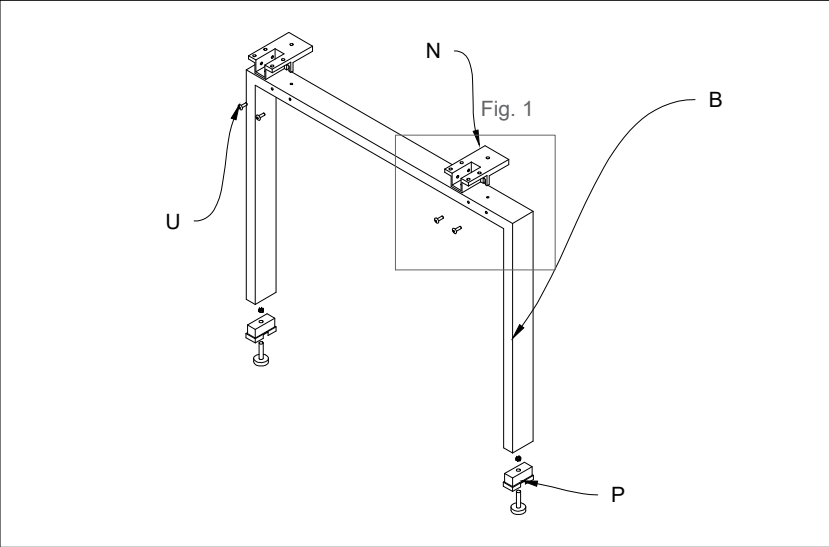
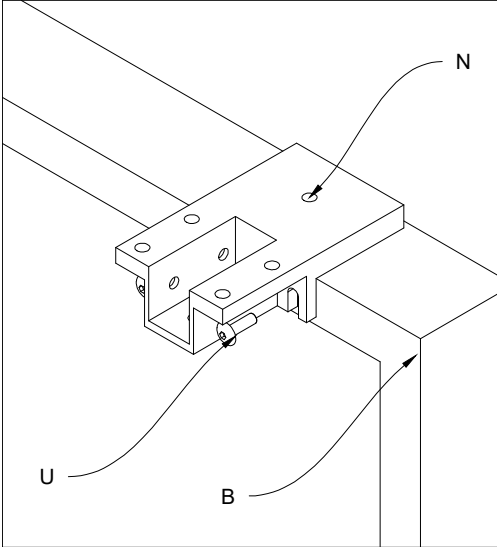

Fig.2 Fissare i bulloni (V e T) nei distanziali (N) con un dado (S) e rondelle (Q), nella struttura
Fig.2 Fasten the bolts (V and T) to the spacers (N) with one nut (S) and washer (Q) on structure

3) Posizionare il piano (A) sopra la struttura.
3) Position the top (A) on top of the structure.

Fig.3 Fissare i bulloni (T e Z) nei distanziali con il piano e la struttura
Fig.3 Fasten the bolts (T and Z) to the spacers in the top and structure

